

JUMO GmbH & Co. KG

Delivery address: Mackenrodtstraße 14
36039 Fulda, Germany
Postal address: 36035 Fulda, Germany
Phone: +49 661 6003-0
Fax: +49 661 6003-607
E-mail: mail@jumo.net
Internet: www.jumo.net

JUMO Instrument Co. Ltd.

JUMO House
Temple Bank, Riverway
Harlow, Essex CM20 2DY, UK
Phone: +44 1279 635533
Fax: +44 1279 635262
E-mail: sales@jumo.co.uk
Internet: www.jumo.co.uk

JUMO Process Control, Inc.

6733 Myers Road
East Syracuse, NY 13057, USA
Phone: 315-437-5866
1-800-554-5866
Fax: 315-437-5860
E-mail: info.us@jumo.net
Internet: www.jumousa.com



ATEX Thermowell for Zone Separation 0/1 or 20/21

with Standard Acceptance Inspection Certificate 3.1 Acc. to DIN EN 10204

Special features

- Zone separation 0/1 or 20/21
- As screw-in sleeve or weld-in sleeve
- Insertion lengths 100, 200, and 300 mm available directly from the factory
- Special lengths are available upon request

Brief description

ATEX thermowells made of stainless steel are used for the separation of zones 0 and 1 or 20 and 21. Screw-in sleeves or weld-in sleeves are available from the factory in insertion lengths 100 mm, 200 mm, and 300 mm. Special lengths up to 500 mm can be manufactured specifically for an application.



Ex identification



II 1/2 G Ex Ga/Gb
II 1/2 D Ex Da/Db

Test confirmation

EPS 12 ATEX 1 423 U

Approvals/approval marks



JUMO GmbH & Co. KG
 Delivery address: Mackenrodtstraße 14
 36039 Fulda, Germany
 Postal address: 36035 Fulda, Germany
 Phone: +49 661 6003-0
 Fax: +49 661 6003-607
 E-mail: mail@jumo.net
 Internet: www.jumo.net

JUMO Instrument Co. Ltd.
 JUMO House
 Temple Bank, Riverway
 Harlow, Essex CM20 2DY, UK
 Phone: +44 1279 635533
 Fax: +44 1279 635262
 E-mail: sales@jumo.co.uk
 Internet: www.jumo.co.uk

JUMO Process Control, Inc.
 6733 Myers Road
 East Syracuse, NY 13057, USA
 Phone: 315-437-5866
 1-800-554-5866
 Fax: 315-437-5860
 E-mail: info.us@jumo.net
 Internet: www.jumousa.com



Technical data

Thermowells made of stainless steel

Material	Thermowell and nipple (pipe connector): stainless steel (1.4571)		
Max. admissible operating temperature *	Temperature °C	Thermowell-Ø	
		10 x 1.5 mm	16 x 1.5 mm
	Maximum admissible pressure in bar		
	100	74	50
	150	71	48
	200	67	45
	300	58	39
400	54	36	
Without load capacity	530	0	0

*observe maximum admissible probe temperature of the respective thermostat version!

JUMO GmbH & Co. KG
 Delivery address: Mackenrodtstraße 14
 36039 Fulda, Germany
 Postal address: 36035 Fulda, Germany
 Phone: +49 661 6003-0
 Fax: +49 661 6003-607
 E-mail: mail@jumo.net
 Internet: www.jumo.net

JUMO Instrument Co. Ltd.
 JUMO House
 Temple Bank, Riverway
 Harlow, Essex CM20 2DY, UK
 Phone: +44 1279 635533
 Fax: +44 1279 635262
 E-mail: sales@jumo.co.uk
 Internet: www.jumo.co.uk

JUMO Process Control, Inc.
 6733 Myers Road
 East Syracuse, NY 13057, USA
 Phone: 315-437-5866
 1-800-554-5866
 Fax: 315-437-5860
 E-mail: info.us@jumo.net
 Internet: www.jumousa.com



Approvals/approval marks

ATEX	EN 600079
Acceptance inspection certificate 3.1	DIN EN 10204

Dimensions

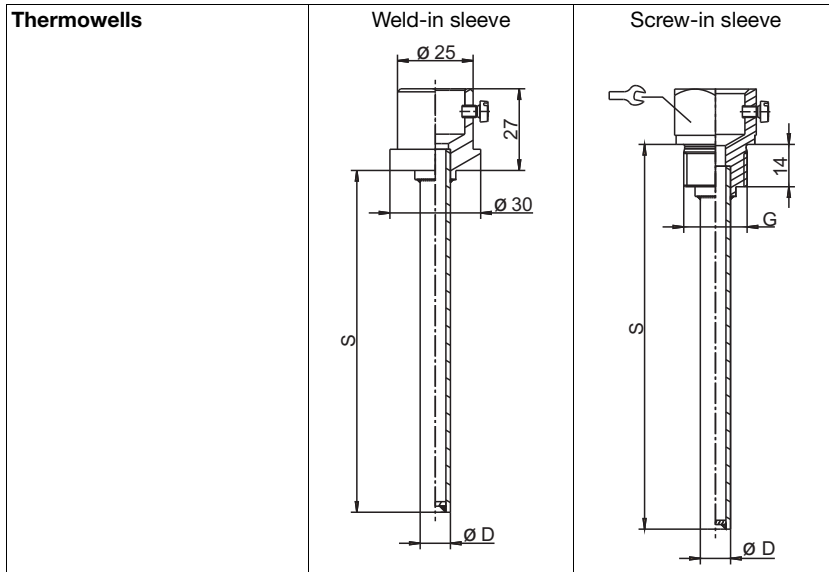

JUMO GmbH & Co. KG
 Delivery address: Mackenrodtstraße 14
 36039 Fulda, Germany
 Postal address: 36035 Fulda, Germany
 Phone: +49 661 6003-0
 Fax: +49 661 6003-607
 E-mail: mail@jumo.net
 Internet: www.jumo.net

JUMO Instrument Co. Ltd.
 JUMO House
 Temple Bank, Riverway
 Harlow, Essex CM20 2DY, UK
 Phone: +44 1279 635533
 Fax: +44 1279 635262
 E-mail: sales@jumo.co.uk
 Internet: www.jumo.co.uk

JUMO Process Control, Inc.
 6733 Myers Road
 East Syracuse, NY 13057, USA
 Phone: 315-437-5866
 1-800-554-5866
 Fax: 315-437-5860
 E-mail: info.us@jumo.net
 Internet: www.jumousa.com



Order details

ATEX thermowell for zone separation 0/1 or 20/21
 with standard acceptance certificate 3.1 acc. to DIN EN 10204

Order code	(1) Basic type
605057	ATEX thermowell for zone separation 0/1 or 20/21
	(2) Basic type extension process connection
20	Screw-in thermowell
22	Weld-in thermowell
	(3) Thread type G
00	Without thread (weld-in sleeve)
13	G 1/2
	(4) Material
20	CrNi Stainless steel
	(5) Insertion length S in mm
100	100
200	200
300	300
...	Special length (specifications in plain text - 50 mm steps)
	(6) Thermowell-Ø D
10	10 mm (for the installation of a temperature probe)
16	16 mm (for the installation of 2 temperature probes, including pressure spring)

Order code:

(1)	(2)	(3)	(4)	(5)	(6)					
605057	/	..	-	..	-	..	-	...	-	..

Order example:

605057	/	20	-	13	-	20	-	200	-	10
--------	---	----	---	----	---	----	---	-----	---	----

Stock versions

Part no.	Type	Process connection	Thread	Material	Insertion length S mm	Thermowell-Ø
60003376	605057/20-13-20-100-10	Screw-in thermowell	G 1/2	CrNi	100	10 mm (for the installation of a temperature probe)
60003377	605057/20-13-20-200-10				200	
60003378	605057/20-13-20-300-10				300	
60003379	605057/22-00-20-100-10	Weld-in thermowell	Without thread		100	
60003380	605057/22-00-20-200-10				200	
60003381	605057/22-00-20-300-10				300	